

Iron-55

Primary X-ray Sources

Annular Sources

Iron-55 electrodeposited as iron metal on a copper ring with tungsten alloy backing, sealed in a welded stainless steel capsule with beryllium window.

Nominal activity*		Capsule	Typical photon output in $\text{hs}^{-1} \text{sp}^{-1}$ photons/sec per steradian* Mn K X-rays	Code and Model number
MBq	mCi			
37	1	X.87/5	0.75×10^6	IEC.8753
185	5		38×10^6	IEC.8755
740	20		15×10^6	IEC.8758

*Tolerance $\pm 20\%$

Recommended working life: 5 years

Quality Control

Wipe test A

Immersion test L

Photon emission checked using a Si(Li) detector.

Total g-impurities checked using a 75 x 75mm NaI crystal.

Total gamma impurities over 100keV ($^{54}\text{Mn} + ^{59}\text{Fe}$) <0.02%

Principal emissions: 5.9keV (Mn K X-rays).

X.87/5

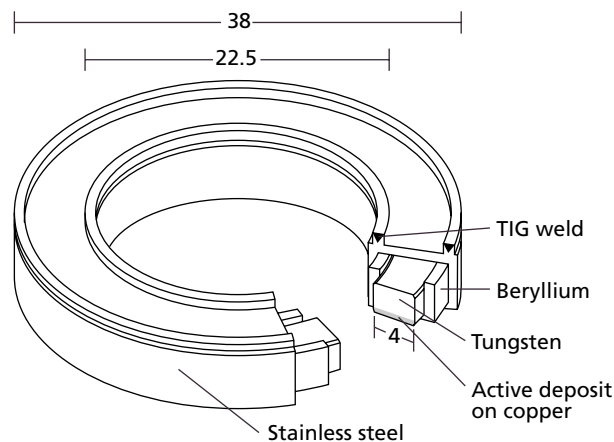

Safety performance testing

ANSI/ISO classification	Model no.
C33344	IEC.A2

Iron-55

Primary X-ray Sources Encapsulated Disc Sources

Iron-55 electrodeposited as iron metal on the face of a copper disc sealed in a welded monel capsule with brazed beryllium window.

Nominal activity* Capsule		Typical photon output in photons/sec per steradian Mn K X-rays	Code
MBq	mCi		
X.133/0			
37	1	0.6×10^6	IEC.1331
185	5	3.5×10^6	IEC.1332
370	10	7×10^6	IEC.1333
740	20	14×10^6	IEC.1335
1850	50	35×10^6	IEC.1336
3700	100	70×10^6	IEC.1337
X.330			
37	1	0.6×10^6	IEC.3301
185	5	3×10^6	IEC.3302
370	10	6×10^6	IEC.3303
740	20	12×10^6	IEC.3305

*Tolerance $\pm 10\%$

Recommended working life: 10 years

Photon emission checked using a thin NaI detector.

Total gamma impurities checked using a 75 x 75mm NaI crystal.

Total gamma impurities over 100keV ($^{54}\text{Mn} + ^{59}\text{Fe}$) <0.02%

Principal emissions: 5.9keV (Mn K X-rays).

Quality Control

Wipe test A

Bubble test D

Immersion test L

X.133/0 X.330

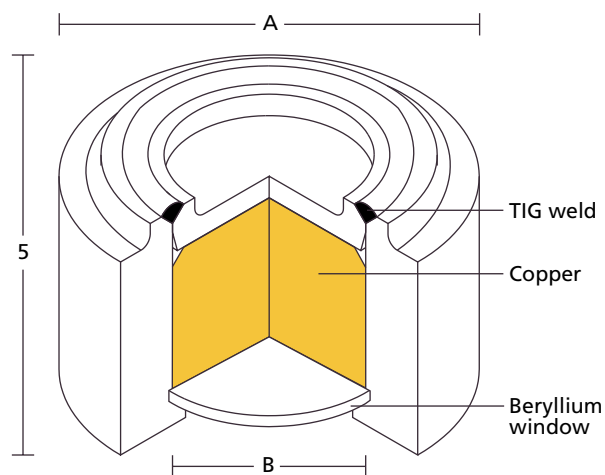

Capsule dimensions and Safety performance

Capsule	Overall diam. 'A' mm	Active diam. 'B' mm	Window diam. 'C' mm	Safety performance testing	
				ANSI/ISO classification	Model number
X.133/0	15.0	10.0	12.0	C54344	IEC.D2
X.330	8.0	3.5	4.5	C44243	IEC.D1

Iron-55

Primary X-ray Sources

Unencapsulated Nickel Coated Sealed Sources

Iron-55 electrodeposited as iron metal on the face of a copper substrate, 12.5mm diam, 3mm thick covered with a protective nickel layer.

The sources are corrosion resistant.

Photon emission checked by proportional counter. Spectral purity checked by radionuclidic assay of raw material.

Disc and line sources to other dimensions can be supplied; enquiries invited.

Nominal activity*		Typical photon output in photons/sec per steradian* Mn K X-rays	Code
MBq	mCi		
37	1	0.65×10^6	IEC.121
185	5	3.25×10^6	IEC.122
370	10	7.25×10^6	IEC.123
740	20	14.50×10^6	IEC.125
1850	50	36.25×10^6	IEC.126

*Tolerance $\pm 20\%$

Recommended working life: 5 years

Quality Control

Wipe test A

Immersion test L

X.0709

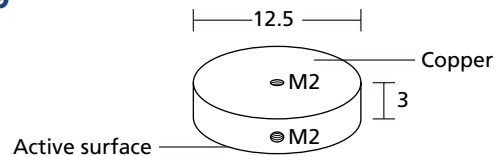

Safety performance testing

ANSI/ISO classification	Model no.
C44342	IEC.A1